

Base Connection A - Ideal for fixing to a beam and block floor or a concrete floor slab cast over the inner skin.

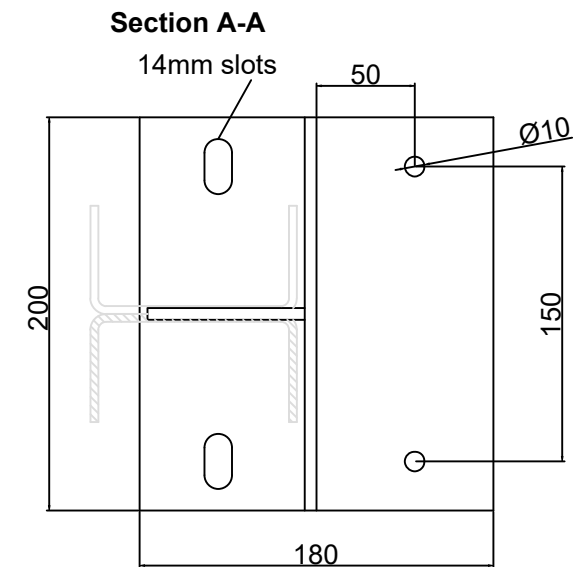

Base Connection B - Ideal for fixing to a concrete floor slab that is not located over the inner skin

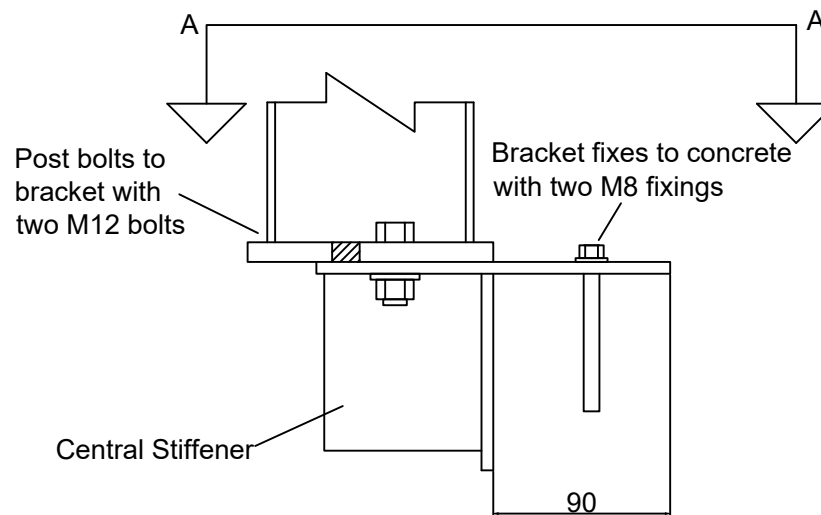
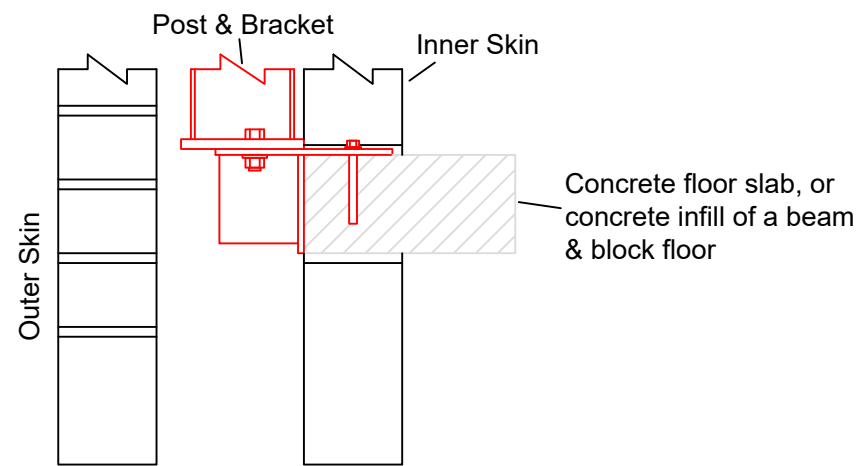
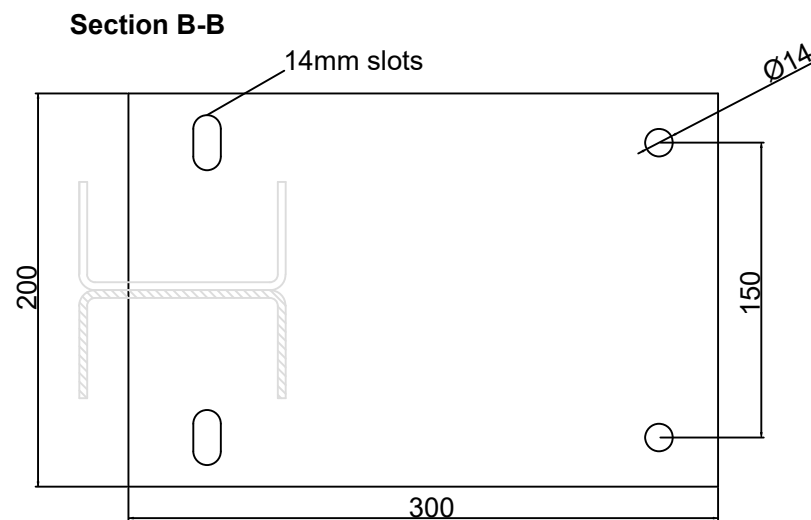
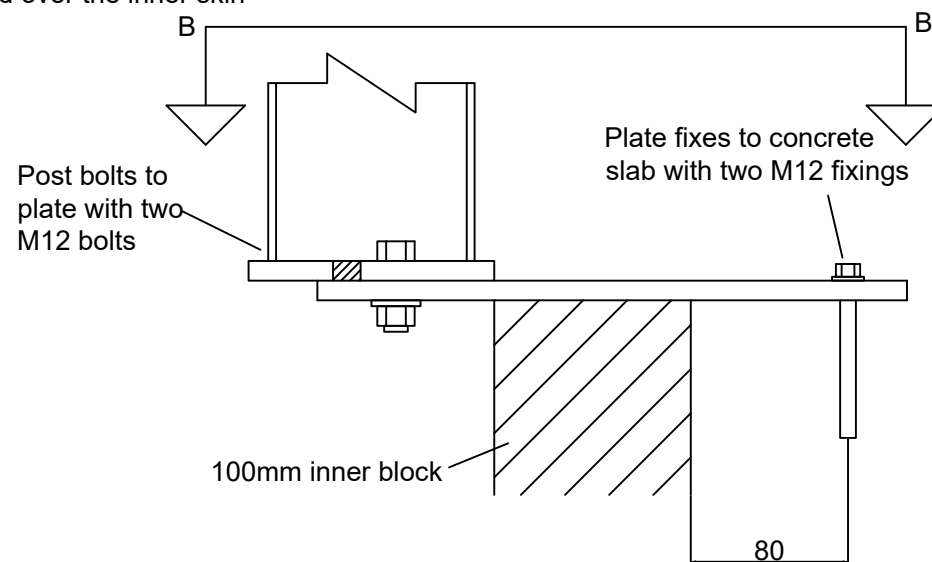
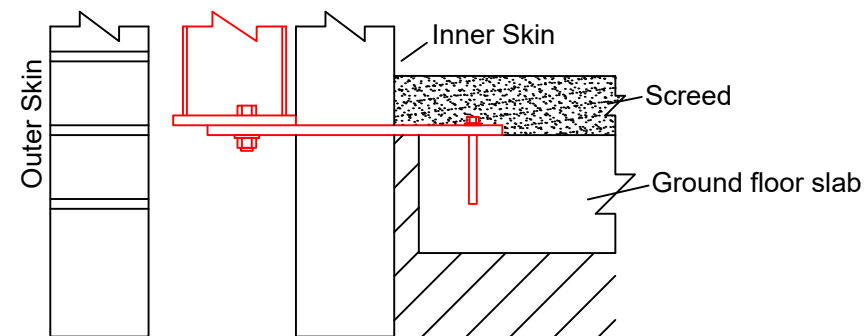

Base Connection C - Ideal for fixing to timber floor joists

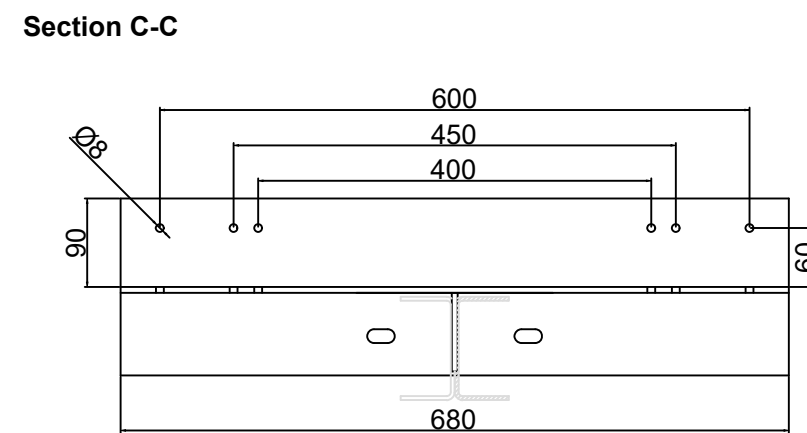
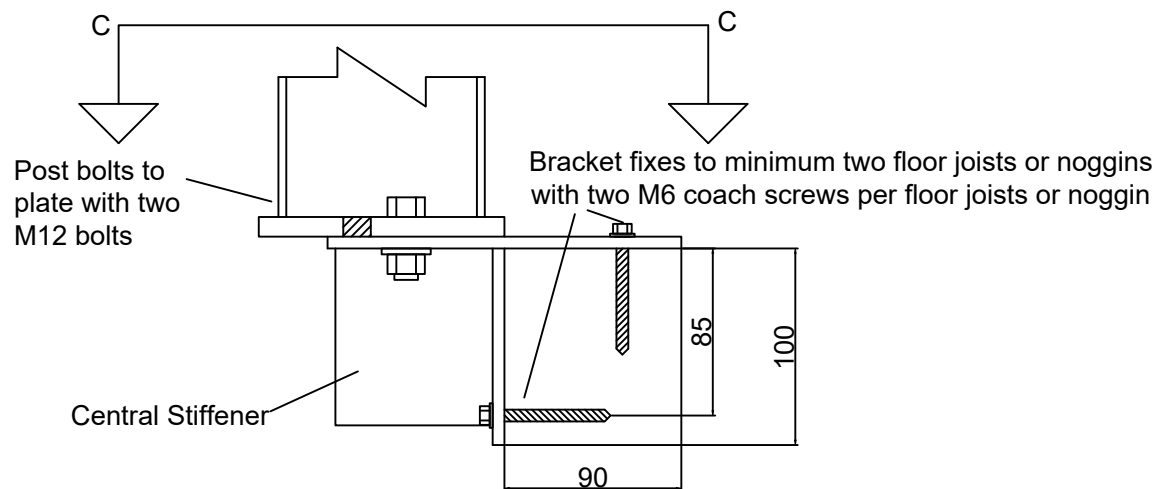
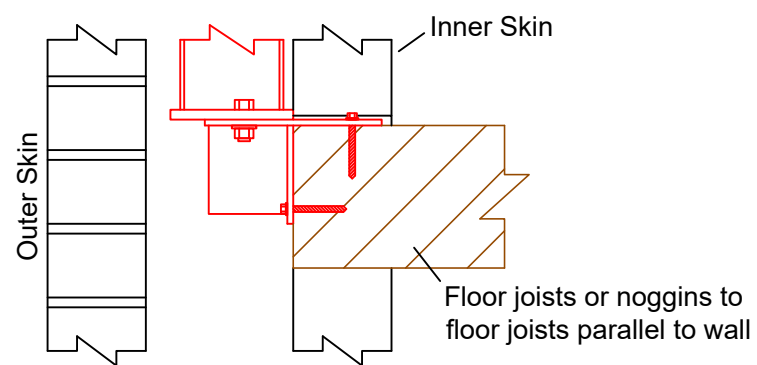

Standard Base Plate to All Posts - Ideal for fixing directly to concrete foundations or to a base bracket.

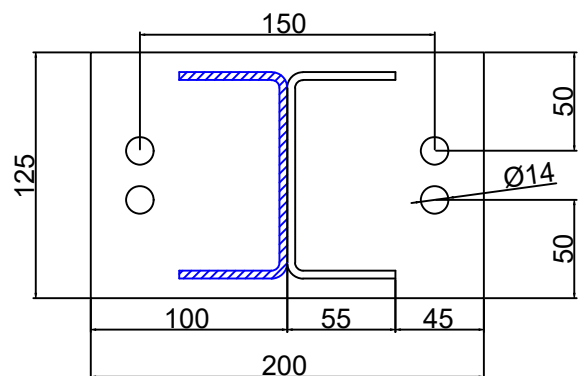

Fixes directly to foundation, or to base bracket. 10mm thick with holes for two M12 fixings. Blue hatched section shows position of doubled up post where required. Please note that although four holes are present, only two are required for fixings. The second set of holes allow the post to be rotated 180° if required when fixing to a connector.

All WP-C105 posts have this base plate as standard unless noted otherwise

The base connections shown in this drawing should be assessed for suitability for the intended use by a competent structural engineer.

If you are unable to obtain advice from a structural engineer, contact us to find which base connection is suitable for your project.

Can't see a base connection that works for you? Contact us for a custom base connection design.

Drawing Title
WP-C105 - Base Connections

Date
17.03.25

Scale
N/A



sales@earlengineering.co.uk
01623 843912

125mm Cavity

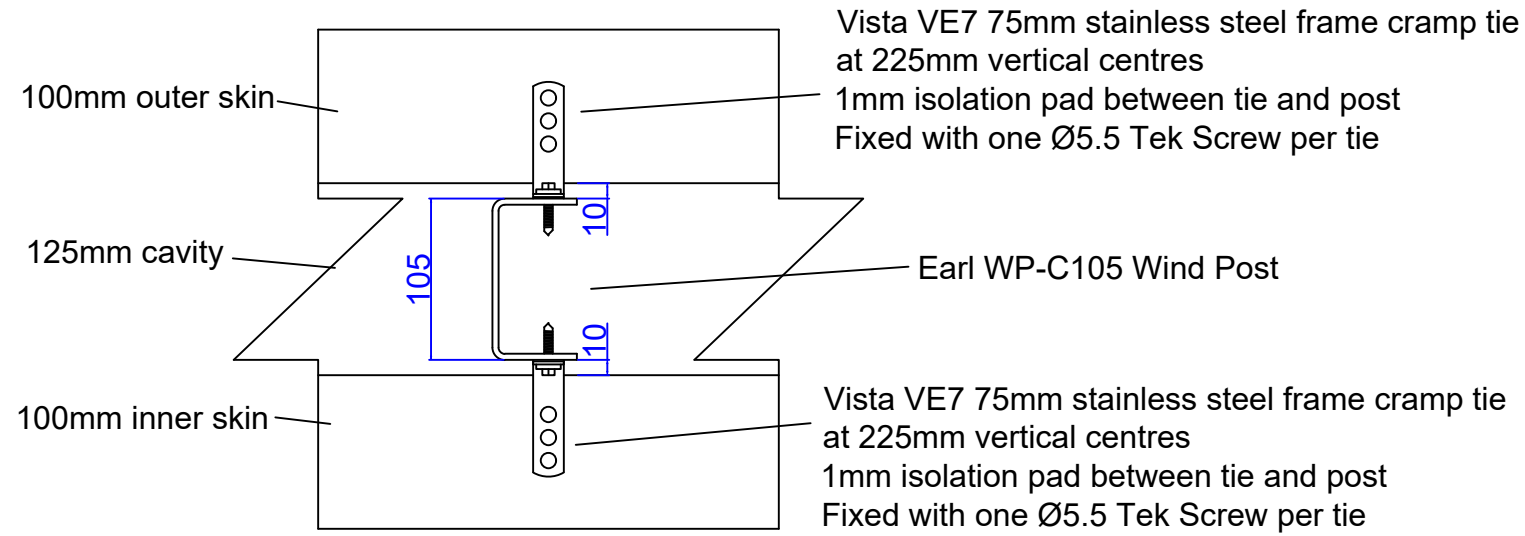

150mm Cavity

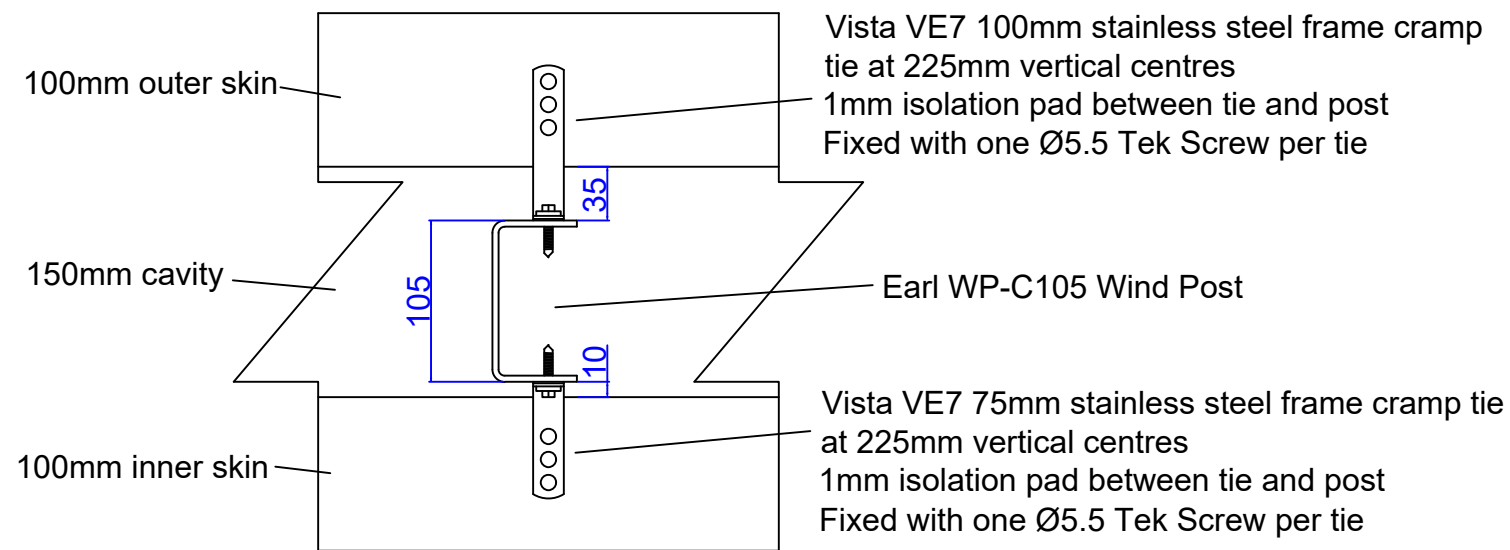

The tie details shown in this drawing provide suitable resistance for the loads declared in our load tables.

Should the installer source alternative ties and fixings, they are responsible for ensuring they are fit for purpose.

The tie lengths shown ensure a minimum of 62.5mm tie embedment into the mortar joint as per tie manufactures requirement when the dimensions shown are achieved.

British Standards recommend a minimum tie embedment of 50mm. Should the dimensions vary to drawn on the left, the installer is to ensure the ties are long enough to achieve the minimum required embedment.

**Unsure?
Contact us for advice.**

Drawing Title
WP-C105 - Masonry Tie Details

Date	Scale
17.03.25	N/A

EARL
—ENGINEERING—

sales@earlengineering.co.uk
01623 843912

Top Connector A - Ideal for fixing to a timber floor or flat roof

Section View

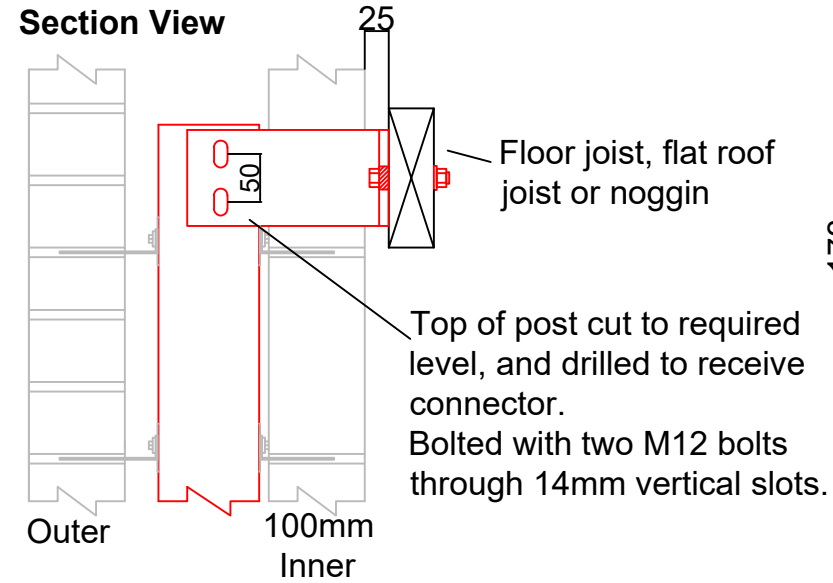

Plan View

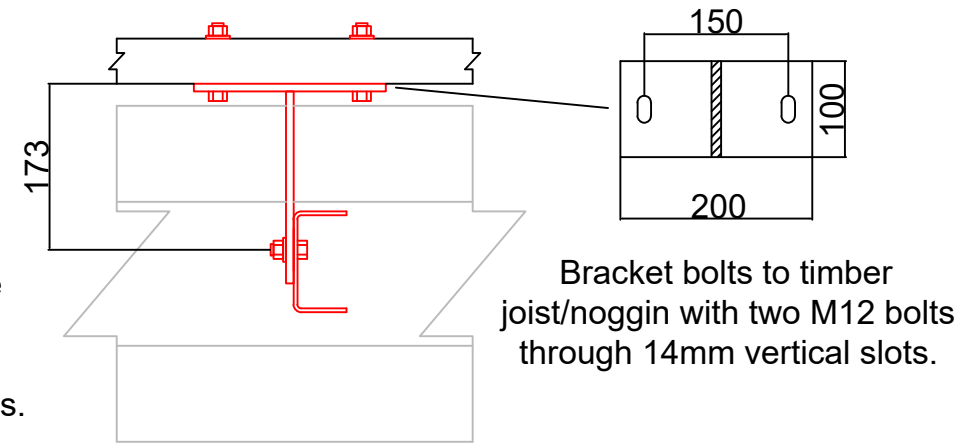

Bracketless Top Connection A

Plan View

Timber joist or noggin positioned tight to web of wind post. Drill post and timber $\text{\O}14$ for two M12 bolts.

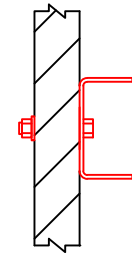

Top Connector B - Ideal for fixing to a timber wall plate, concrete slab, or concrete infill of beam and block

Section View

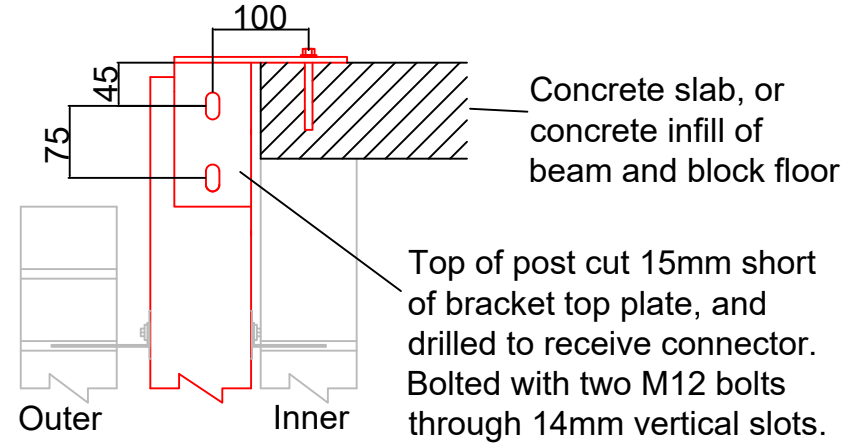
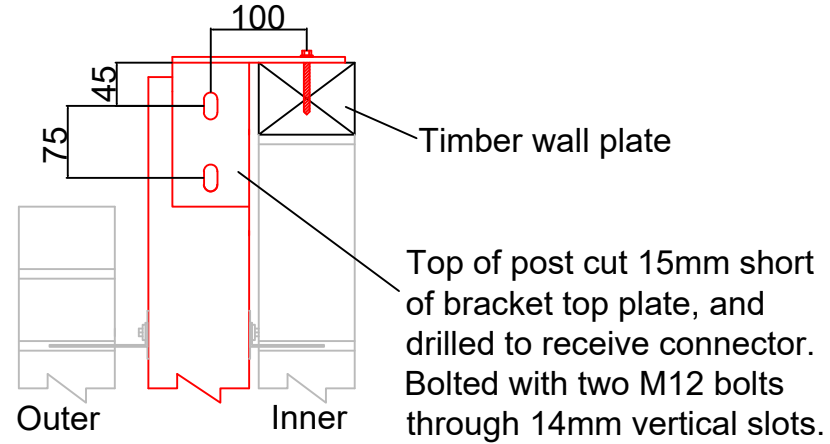

Bracketless Top Connection B

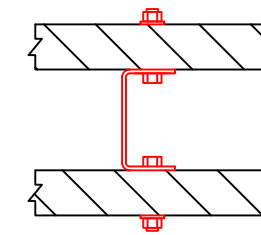

Plan View

Timber noggins positioned tight to both flanges of wind post. Drill post and timber $\text{\O}14$ for one M12 bolt per noggin.

The top connections shown in this drawing should be assessed for suitability for the intended use by a competent structural engineer.

If you are unable to obtain advice from a structural engineer contact us to find which connection is suitable for your project.

Can't see a connection that works for you? Contact us for a custom base connection design.

Top Connector C - Ideal for fixing to the web of a steel beam, timber joists or noggins

Plan View

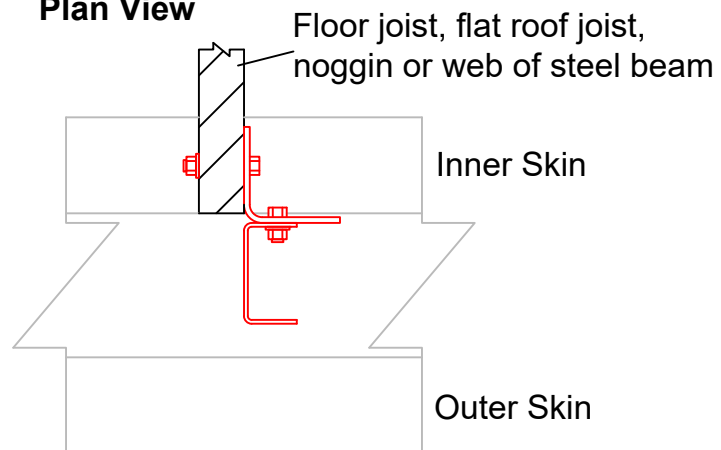

Section View

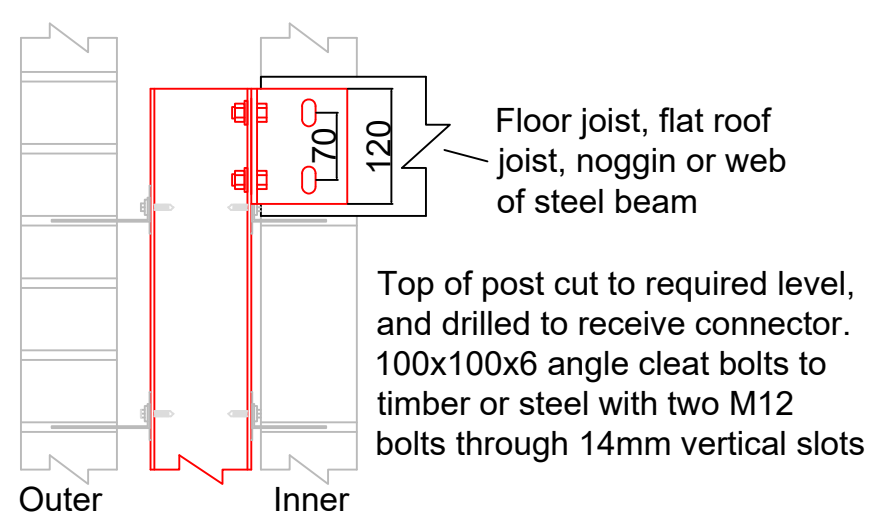

100x100x6 angle cleat bolts to top of post with two M12 bolts through 14mm horizontal slots
Minimum 20mm edge of post to centre of drilled hole.

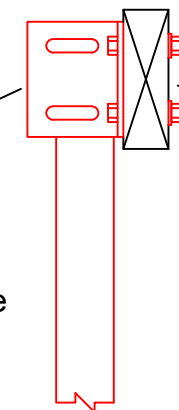

Floor joist, flat roof joist, noggin or web of steel beam

Drawing Title

WP-C105 - Masonry Tie Details

Date

17.03.25

Scale

N/A

EARL
—ENGINEERING—

sales@earlengineering.co.uk
01623 843912